

**GOCE DELCEV UNIVERSITY, SHTIP, NORTH MACEDONIA
FACULTY OF ELECTRICAL ENGINEERING**

ETIMA 2021

FIRST INTERNATIONAL CONFERENCE

19-21 OCTOBER, 2021



**TECHNICAL SCIENCES APPLIED IN ECONOMY,
EDUCATION AND INDUSTRY**



УНИВЕРЗИТЕТ „ГОЦЕ ДЕЛЧЕВ” - ШТИП
ЕЛЕКТРОТЕХНИЧКИ ФАКУЛТЕТ

UNIVERSITY „GOCE DELCHEV” - SH TIP
FACULTY OF ELECTRICAL ENGINEERING

ПРВА МЕЃУНАРОДНА КОНФЕРЕНЦИЈА
FIRST INTERNATIONAL CONFERENCE

ЕТИМА / ЕТИМА 2021

ЗБОРНИК НА ТРУДОВИ
CONFERENCE PROCEEDINGS

19-21 Октомври 2021 | 19-21 October 2021

Главен и одговорен уредник / Editor in Chief

Проф.д-р Сашо Гелев
Prof.d-r Saso Gelev

Јазично уредување / Language Editor

Весна Ристова (Македонски) / Vesna Ristova (Macedonian)

Техничко уредување / Technical Editing

Доц.д-р Далибор Серафимовски / d-r Dalibor Serafimovski

Издавач / Publisher

Универзитет „Гоце Делчев“ - Штип / University Goce Delchev - Stip
Електротехнички факултет / Faculty of Electrical Engineering

Адреса на организационен комитет / Adress of the organizational committee

Универзитет „Гоце Делчев“ – Штип / University Goce Delchev - Stip
Електротехнички факултет / Faculty of Electrical Engineering
Адреса: ул. „Крсте Мисирков“ бр. 10-А / Adress: Krste Misirkov, 10 - A
Пош. фах 201, Штип - 2000, С.Македонија / PO BOX 201, Stip 2000, North Macedonia
E-mail: conf.etf@ugd.edu.mk

CIP - Каталогизација во публикација
Национална и универзитетска библиотека "Св. Климент Охридски", Скопје

62-049.8(062)
004-049.8(062)

МЕЃУНАРОДНА конференција ЕТИМА (1 ; 2021)
Зборник на трудови [Електронски извор] / Прва меѓународна
конференција ЕТИМА 2021, 19-21 Октомври 2021 = Conference proceedings /
First international conferece ЕТИМА 2021, 19-21 October 2021 ; [главен и
одговорен уредник Сашо Гелев]. - Штип: Универзитет "Гоце Делчев",
Електротехнички факултет = Shtip: University "Goce Delchev", Faculty of
Electrical Engineering, 2021

Начин на пристапување (URL): <https://js.ugd.edu.mk/index.php/etima>. -
Текст во PDF формат, содржи 358 стр.илустр. - Наслов преземен од
екранот. - Опис на изворот на ден 15.10.2021. - Трудови на мак. и англ.
јазик. - Библиографија кон трудовите

ISBN 978-608-244-823-7

1. Напор. ств. насл.

а) Електротехника -- Примена -- Собири б) Машинство -- Примена -- Собири
в) Автоматика -- Примена -- Собири г) Информатика -- Примена -- Собири

COBISS.MK-ID 55209989



Прва меѓународна конференција ЕТИМА
19-21 Октомври 2021
First International Conference ETIMA
19-21 October 2021

**ОРГАНИЗАЦИОНЕН ОДБОР
ORGANIZING COMMITTEE**

Василија Шарац / Vasilija Sarac

Електротехнички факултет,
Универзитет „Гоце Делчев” - Штип, Северна Македонија
Faculty of Electrical Engineering,
Goce Delchev University - Stip, North Macedonia

Сашо Гелев / Saso Gelev

Електротехнички факултет,
Универзитет „Гоце Делчев” - Штип, Северна Македонија
Faculty of Electrical Engineering,
Goce Delchev University - Stip, North Macedonia

Тодор Чекеровски / Todor Cekеровски

Електротехнички факултет,
Универзитет „Гоце Делчев” - Штип, Северна Македонија
Faculty of Electrical Engineering,
Goce Delchev University - Stip, North Macedonia

Далибор Серафимовски / Dalibor Serafimovski

Електротехнички факултет,
Универзитет „Гоце Делчев” - Штип, Северна Македонија
Faculty of Electrical Engineering,
Goce Delchev University - Stip, North Macedonia

Маја Кукушева Панева / Maja Kukuseva Paneva

Електротехнички факултет,
Универзитет „Гоце Делчев” - Штип, Северна Македонија
Faculty of Electrical Engineering,
Goce Delchev University - Stip, North Macedonia

Билјана Читкушева Димитровска / Biljana Citkuseva Dimitrovska

Електротехнички факултет,
Универзитет „Гоце Делчев” - Штип, Северна Македонија
Faculty of Electrical Engineering,
Goce Delchev University - Stip, North Macedonia

Весна Конзулова / Vesna Konzulova

Електротехнички факултет,
Универзитет „Гоце Делчев” - Штип, Северна Македонија
Faculty of Electrical Engineering,
Goce Delchev University - Stip, North Macedonia



Прва меѓународна конференција ЕТИМА
19-21 Октомври 2021
First International Conference ETIMA
19-21 October 2021

**ПРОГРАМСКИ И НАУЧЕН ОДБОР
SCIENTIFIC COMMITTEE**

Со Ногучи / So Noguchi

Висока школа за информатички науки и технологии
Универзитет Хокаидо, Јапонија
Graduate School of Information Science and Technology
Hokkaido University, Japan

Диониз Гашпаровски / Dionýz Gašparovský

Факултет за електротехника и информатички технологии,
Словачки Технички Универзитет во Братислава, Словачка
Faculty of Electrical Engineering and Information Technology
Slovak Technical University in Bratislava, Slovakia

Антон Белан / Anton Belán

Факултет за електротехника и информатички технологии
Словачки Технички Универзитет во Братислава, Словачка
Faculty of Electrical Engineering and Information Technology
Slovak Technical University in Bratislava, Slovakia

Георги Иванов Георгиев / Georgi Ivanov Georgiev,

Технички Универзитет во Габрово, Бугарија
Technical University in Gabrovo, Bulgaria

Ивелина Стефанова Балабанова / Ivelina Stefanova Balabanova,

Технички Универзитет во Габрово, Бугарија
Technical University in Gabrovo, Bulgaria

Бојан Димитров Карапeneв / Boyan Dimitrov Karapenev

Технички Универзитет во Габрово, Бугарија
Technical University in Gabrovo, Bulgaria

Сашо Гелев / Saso Gelev

Електротехнички факултет,
Универзитет „Гоце Делчев“ - Штип, Северна Македонија
Faculty of Electrical Engineering,
Goce Delchev University - Stip, North Macedonia

Влатко Чингоски / Vlatko Cingoski
Електротехнички факултет,
Универзитет „Гоце Делчев” - Штип, Северна Македонија
Faculty of Electrical Engineering,
Goce Delchev University - Stip, North Macedonia

Божо Крстајиќ / Bozo Krstajic
Електротехнички факултет
Универзитет во Црна Гора, Црна Гора
Faculty of Electrical Engineering,
University in Montenegro, Montenegro

Милован Радуловиќ / Milovan Radulovic
Електротехнички факултет
Универзитет во Црна Гора, Црна Гора
Faculty of Electrical Engineering,
University in Montenegro, Montenegro

Гоце Стефанов / Goce Stefanov
Електротехнички факултет,
Универзитет „Гоце Делчев” - Штип, Северна Македонија
Faculty of Electrical Engineering,
Goce Delchev University - Stip, North Macedonia

Мирјана Периќ / Mirjana Peric
Електронски факултет
Универзитет во Ниш, Србија
Faculty of Electronic Engineering,
University of Nis, Serbia

Ана Вучковиќ / Ana Vuckovic
Електронски факултет
Универзитет во Ниш, Србија
Faculty of Electronic Engineering,
University of Nis, Serbia

Тодор Чекеровски / Todor Cekеровски
Електротехнички факултет,
Универзитет „Гоце Делчев” - Штип, Северна Македонија
Faculty of Electrical Engineering,
Goce Delchev University - Stip, North Macedonia

Далибор Серафимовски / Dalibor Serafimovski
Електротехнички факултет,
Универзитет „Гоце Делчев” - Штип, Северна Македонија
Faculty of Electrical Engineering,
Goce Delchev University - Stip, North Macedonia

Мирослава Фаркаш Смиткова / Miroslava Farkas Smitková

Факултет за електротехника и информациони технологии
Словачки Технички Универзитет во Братислава, Словачка
Faculty of Electrical Engineering and Information Technology
Slovak Technical University in Bratislava, Slovakia

Петер Јанига / Peter Janiga

Факултет за електротехника и информациони технологии
Словачки Технички Универзитет во Братислава, Словачка
Faculty of Electrical Engineering and Information Technology
Slovak Technical University in Bratislava, Slovakia

Јана Радичова / Jana Raditschová,

Факултет за електротехника и информациони технологии
Словачки Технички Универзитет во Братислава, Словачка
Faculty of Electrical Engineering and Information Technology
Slovak Technical University in Bratislava, Slovakia

Драган Миновски / Dragan Minovski

Електротехнички факултет,
Универзитет „Гоце Делчев” - Штип, Северна Македонија
Faculty of Electrical Engineering,
Goce Delchev University - Stip, North Macedonia

Василија Шарац / Vasilija Sarac

Електротехнички факултет,
Универзитет „Гоце Делчев” - Штип, Северна Македонија
Faculty of Electrical Engineering,
Goce Delchev University - Stip, North Macedonia

Александар Туцаров / Aleksandar Tudzarov

Електротехнички факултет,
Универзитет „Гоце Делчев” - Штип, Северна Македонија
Faculty of Electrical Engineering,
Goce Delchev University - Stip, North Macedonia

Владимир Талевски / Vladimir Talevski

Електротехнички факултет,
Универзитет „Гоце Делчев” - Штип, Северна Македонија
Faculty of Electrical Engineering,
Goce Delchev University - Stip, North Macedonia



Прва меѓународна конференција ЕТИМА First International Conference ETIMA

PREFACE

The Faculty of Electrical Engineering at University Goce Delcev (UGD), has organized the International Conference *Electrical Engineering, Informatics, Machinery and Automation - Technical Sciences applied in Economy, Education and Industry-ETIMA*.

ETIMA has a goal to gather the scientists, professors, experts and professionals from the field of technical sciences in one place as a forum for exchange of ideas, to strengthen the multidisciplinary research and cooperation and to promote the achievements of technology and its impact on every aspect of living. We hope that this conference will continue to be a venue for presenting the latest research results and developments on the field of technology.

Conference ETIMA was held as online conference where contributed more than sixty colleagues, from six different countries with forty papers.

We would like to express our gratitude to all the colleagues, who contributed to the success of ETIMA'21 by presenting the results of their current research activities and by launching the new ideas through many fruitful discussions.

We invite you and your colleagues also to attend ETIMA Conference in the future. One should believe that next time we will have opportunity to meet each other and exchange ideas, scientific knowledge and useful information in direct contact, as well as to enjoy the social events together.

The Organizing Committee of the Conference

ПРЕДГОВОР

Меѓународната конференција *Електротехника, Технологија, Информатика, Машинство и Автоматика-технички науки во служба на економија, образование и индустрија-ЕТИМА* е организирана од страна на Електротехничкиот факултет при Универзитетот Гоце Делчев.

ЕТИМА има за цел да ги собере на едно место научниците, професорите, експертите и професионалците од полето на техничките науки и да представува форум за размена на идеи, да го зајканува мултидисциплинарното истражување и соработка и да ги промовира технолошките достигнувања и нивното влијание врз секој аспект од живеењето. Се надеваме дека оваа конференција ќе продолжи да биде настан на кој ќе се презентираат најновите резултати од истражувањата и развојот на полето на технологијата.

Конференцијата ЕТИМА се одржа online и на неа дадоа свој допринос повеќе од шеесет автори од шест различни земји со четириесет труда.

Сакаме да ја искажеме нашата благодарност до сите колеги кои допринесоа за успехот на ЕТИМА'21 со презентирање на резултати од нивните тековни истражувања и со лансирање на нови идеи преку многу плодни дискусии.

Ве покануваме Вие и Вашите колеги да земете учество на ЕТИМА и во иднина. Веруваме дека следниот пат ќе имаме можност да се сретнеме, да размениме идеи, знаење и корисни информации во директен контакт, но исто така да уживаме заедно и во друштвените настани.

Организационен одбор на конференцијата

Содржина / Table of Contents

ASSESSING DIGITAL SKILLS AND COMPETENCIES OF PUBLIC ADMINISTRATION AND DEFINING THEIR PROFICIENCY LEVEL.....	12
PWM OPERATION OF SYNCHRONOUS PERMANENT MAGNET MOTOR.....	21
SPEED REGULATION OF INDUCTION MOTOR WITH PWM INVERTER.....	30
WI-FI SMART POWER METER	42
RF SENSOR SMART NETWORK.....	50
FREQUENCY SINUS SOURCE.....	62
MEASUREMENT ON COMPENSATION CAPACITANCE IN INDUCTIVE NETWORK BY MICROCONTROLLER	70
ИЗРАБОТКА НА ВЕШТ НАОД И МИСЛЕЊЕ ОД ОБЛАСТА НА ЕЛЕКТРОТЕХНИЧКИТЕ НАУКИ.....	79
SIMULATION OF AN INDUSTRIAL ROBOT WITH THE HELP OF THE MATLAB SOFTWARE PACKAGE.....	86
BATTERY ENERGY STORAGE SYSTEMS AND TECHNOLOGIES:A REVIEW ..	95
POWER-TO-X TECHNOLOGIES.....	105
NEW INNOVATIVE TOURISM PRODUCT FOR REANIMATING RURAL AREAS	115
PROPOSED MODEL FOR BETTER ENGLISH LANGUAGE ACQUISITION, BASED ON WEARABLE DEVICES.....	123
OPEN SOURCE LEARNING PLATFORM – MOODLE	132
СПОРЕДБЕНА ТЕХНО-ЕКОНОМСКА АНАЛИЗА ПОМЕЃУ ТЕРМИЧКИ ИЗОЛИРАН И ТЕРМИЧКИ НЕИЗОЛИРАН СТАНБЕН ОБЈЕКТ	139
COMPARISON OF PERT AND MONTE CARLO SIMULATION	149
E-LEARNING – CYBER SECURITY CHALLENGES AND PROTECTION MECHANISMS	156
SECURITY AND PRIVACY WITH E-LEARNING SOFTWARE.....	164
ROOTKITS – CYBER SECURITY CHALLENGES AND MECHANISMS FOR PROTECTION	174
TOOLS AND TECHNIQUES FOR MITIGATION AND PROTECTION AGAINST SQL INJECTION ATTACKS	182
INFLUENCE OF ROTATION ANGLE OF LUMINAIRES WITH ASYMMETRICAL LUMINOUS INTENSITY DISTRIBUTION CURVE ON CALCULATED PHOTOMETRIC PARAMETERS.....	189
PHOTOMETRIC PARAMETERS OF LED LUMINAIRES WITH SWITCHABLE CORRELATED COLOUR TEMPERATURE	197
ENERGY-EFFICIENT STREET LIGHTING SYSTEM OF THE CITY OF SHIP USING SOLAR ENERGY AND LED TECHNOLOGY.....	204
NANOTECHNOLOGY–BASED BIOSENSORS IN DRUG DELIVERY SYSTEMS: A REVIEW.....	212

IOT SYSTEM FOR SHORT-CIRCUIT DETECTION OF DC MOTOR AT EKG-15 EXCAVATOR	222
DESIGN OF A PHOTOVOLTAIC POWER PLANT	231
DEVELOPMENT OF COMPUTER SOFTWARE FOR CREATING CHOREOGRAPHY	241
AUTOMATED SYSTEM FOR SMART METER TESTING.....	249
INFLUENCE DIMING OF LED LAMPS TO ELECTRICAL PARAMETERS	255
INRUSH CURRENT OF LAMP.....	261
COMPLEX EVALUATION MODEL OF A SMALL-SCALE PHOTOVOLTAIC INSTALLATION PROFITABILITY	269
IMPACT OF FAULTS IN TRANSMISSION AND DISTRIBUTION NETWORK ON VOLTAGE SAGS	278
ON APPLICABILITY OF BLACK-SCHOLES MODEL TO MSE	290
ACOUSTIC SIGNAL DENOISING BASED ON ROBUST PRINCIPAL COMPONENT ANALYSIS	300
INVESTIGATION OF EFFICIENCY ASPECTS IN 3×3 PHOTOVOLTAIC PLANT USING MODEL OF SHADING	309
PROGRESS OF NO-INSULATION HTS MAGNET DEVELOPMENT TOWARDS ULTRA-HIGH MAGNETIC FIELD GENERATION.....	319
GRID-CONNECTED HYBRID PV SYSTEM WITH BATTERY STORAGE.....	326
INVESTIGATION ON STABILITY OF PANCAKE COILS WOUND WITH BUNDLED MULTIPLE REBCO CONDUCTORS	336
ON-LINE МУЛТИМЕДИСКИ ОБРАЗОВНИ КАРТИЧКИ	343
АЛГОРИТАМОТ „ВЕШТАЧКА КОЛОНИЈА НА ПЧЕЛИ“	352



PWM OPERATION OF SYNCHRONOUS PERMANENT MAGNET MOTOR

*Vasilija Sarac*¹

¹Faculty of Electrical Engineering, University Goce Delcev, email: vasilija.sarac@ugd.edu.mk

Abstract

The paper presents a simulation circuit in Simulink of 2.2. kW synchronous permanent magnet motor, supplied by pulse width inverter (PWM inverter) with two closed control loops per rotor angle and motor current. The various motor operating regimes are simulated at and above the rated speed and with different step loads. The obtained results present the motor normal operation with rated speed and load as well as its operation above the rated speed where the effect of the field weakening can be observed. At higher speeds, the torque is considerably reduced and in the case of rated load at higher speeds, the motor cannot maintain the synchronism. Besides motor speed, motor current, torque, and output voltage from the inverter can be analyzed, from the simulation results. The analysed control scheme is useful for the analysis of motor operation at various speeds.

Keywords

Synchronous permanent magnet motor, PWM inverter, field –weakening

Introduction

Synchronous permanent magnet motors (SPMM) have gained popularity due to their outstanding performances such as high efficiency and power factor considerable higher than at their main competitor-three phase squirrel cage asynchronous motor. Their main drawback is the inability to direct start with the power supply from the mains. The development of power electronics has promoted this type of motor as the main competitor of the asynchronous motor, especially at high-speed applications.

The permanent magnet synchronous motor is started with the aid of inverter which also regulates the motor speed in wide operating range. In range above the rated speed (base speed) motor enters the field weakening region where the voltage is limited by the available voltage from the inverter. In the same time the induced voltage is proportional to rotor speed while motor torque is proportional to motor current and flux. At low speed, the rated stator current and the rated excitation flux are used to obtain the rated torque. The voltage and the output power, both, rise linearly with the speed. This operating range is referred to as constant-torque or constant-flux region. Above rated speed, the voltage is kept constant and the flux is decreased (weakened). The torque is inversely proportional to the speed increase. As the power is constant beyond the rated speed, this is called constant-power region or field weakening region.

Over the last two decades various control techniques of the inverters have been developed. In [7] a novel field-weakening algorithm which is robust to flux linkage uncertainty is introduced. Field weakening problem is formulated as an optimization problem which is solved online using projected fast gradient method. Based on current research into the mathematical model of the permanent magnet synchronous motor (PMSM) and the feedback linearization theory, a control strategy established upon feedback linearization is proposed in [8]. Compared with three-phase motors, multi-phase motor speed control systems have many advantages, which

make them to have good prospects in many fields, such as the control system of electric vehicle power equipment. In these control systems, it is necessary for the motor to have a wider speed range [9]. Comparison of the operation in field-weakening region of various types of the synchronous motors has been described in [5]. Other authors focus on optimization of the motor itself in terms of improving the efficiency, dynamic characteristics and reducing the cogging torque [1], [2].

The paper presents simulation circuit in Simulink of 2.2. kW synchronous permanent magnet motor, supplied by pulse width inverter (PWM inverter) with two closed control loops per rotor angle and motor current. The various motor operating regimes are simulated at and above rated speed and with different step loads. The obtained results present the motor normal operation with rated speed and load as well as the operation above the rated speed where the effect of the field weakening can be observed. At higher speed the torque is considerably reduced and in case of rated load at higher speeds, the motor cannot maintain the synchronism. Besides motor speed, motor current, torque and output voltage from the inverter can be analysed, from the simulation results. The analysed control scheme is useful for analysis of motor operation at various speeds. The model is universal and can be used for arbitrary synchronous permanent magnet motor by inputting the adequate motor parameters. Further research should be focused on improving the distortion of the motor current from the harmonics, present due to the PWM inverter.

2. Methodology and simulation circuit

The synchronous motors have been known for high efficiency and power factor which are their main advantages over asynchronous motors. Their main drawback, besides the price, is the inability of self-starting i.e. they require the inverter circuit for starting and operation. A permanent magnet synchronous motor requires a control system, for example, a variable frequency drive.

There are many control techniques implemented in control systems. The choice of the optimal control method mainly depends on the task that is put in front of the electric drive. The main methods for controlling a permanent magnet synchronous motor are shown in the Table 1 [3].

Table 1 Control strategies of SPMM

Control			Advantages	Disadvantages	
nSinusoidal	Scalar		Simple control scheme	Control is not optimal, nor suitable for tasks with the variable load. Loss of control is possible	
	Vector	Field oriented control	With position sensor	Smooth and precise setting of the rotor position and motor rotation speed, large control range	Requires rotor position sensor and powerful microcontroller inside the control system
			Without position sensor	No rotor position control is required. Smooth and precise setting of the rotor position and motor rotation speed. Large control range, but less than with the position sensor	Sensorless field oriented control over full speed range is possible only for PMSM with a salient rotor, a powerful system is required
	Direct torque control		A simple control circuit, good dynamic performance, wide control range, no rotor position sensor is required	High torque and current ripple	

Trapezoidal	Open-loop		Simple control scheme	Control is not optimal, nor suitable for tasks where there is a variable load, loss of control is possible
	Closed-loop	With position sensor (Hall sensors)	Simple control scheme	Hall sensor required. There are torque ripples. It is intended for the control of PMSM with trapezoidal back EMF. When controlling PMSM with sinusoidal back EMF, the average torque is lower by 5 %.
		Without sensor	A more powerful control system required	

Source: <https://en.engineering-solutions.ru/motorcontrol/pmsm>

In this paper a 2.2 kW motor with sinusoidal back EMF is analyzed in Simulink with the aid of simulation circuit presented in Fig. 1.

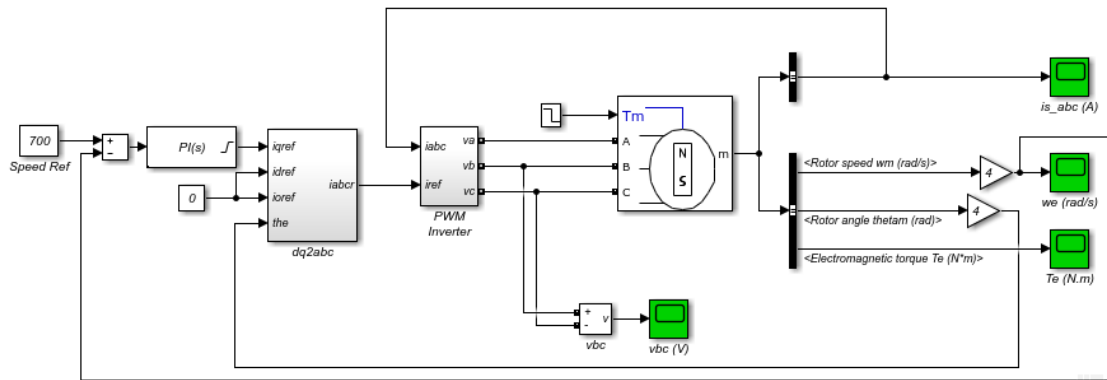

Fig. 1. Synchronous permanent magnet motor fed by the inverter

The motor data are presented in Table 2. They are based on analytical calculations of the motor. Besides motor data also the steady-state characteristics of efficiency, current and output power are presented in Figure. 2. The data presented in Table 2 and Fig. 2 can serve for the verification of the obtained results by the simulation circuit in Simulink.

Table 2 Data of PMSM

Parameter	Value
rated power (W)	2,200
rated current (A)	3.56
rated speed (rpm)	1,500
efficiency (%)	93.7
power factor (/)	0.99
torque angle (°)	18.5
no-load current (A)	0.3

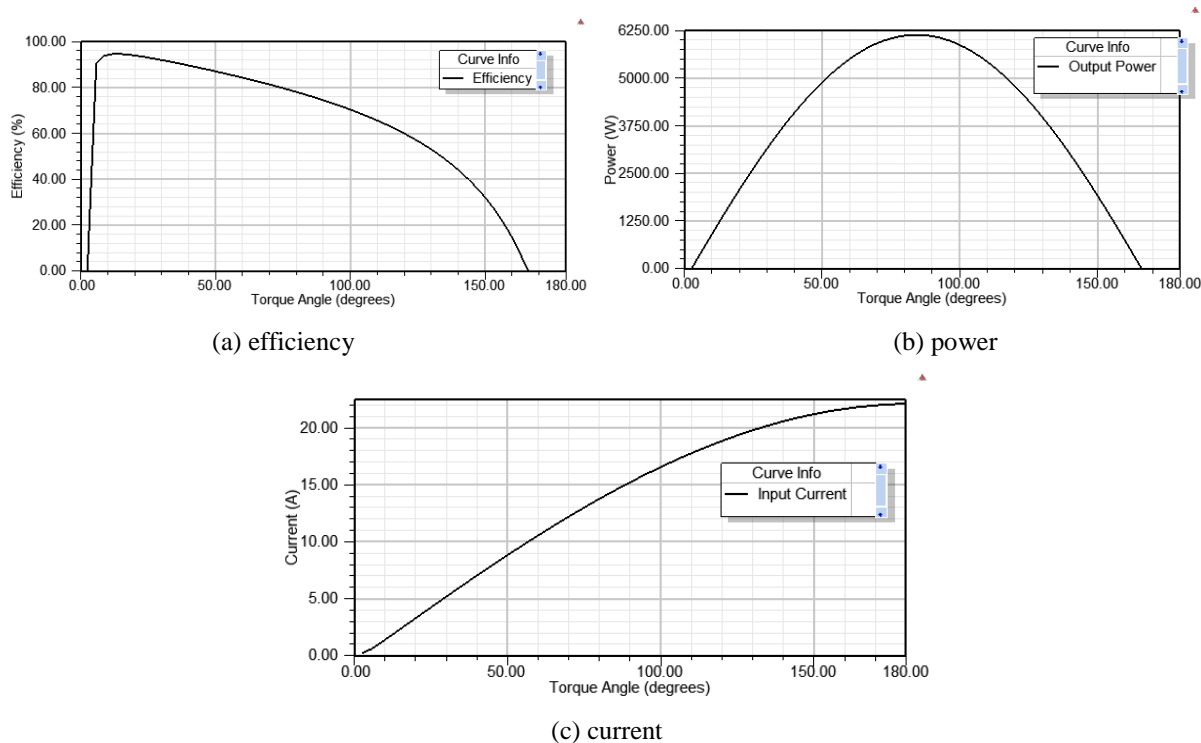

Fig. 2. Steady-state characteristics of efficiency, power, and current

The simulation circuit has two control loops. The inner loop regulates the motor's stator currents. The outer loop controls the motor's speed. The reference speed is set at the input of the PWM inverter. The motor model has a round type of rotor with sinusoidal back EMF. The EMF and the flux density of the motor are presented in Fig.3. The load is applied to the motor and in this model the step load is used. As an output from the simulation circuit the motor speed, current and torque are obtained. By setting the values of reference speed and of the step load various operating regimes can be simulated i.e. with rated speed and above the rated speed combined with various step loads.

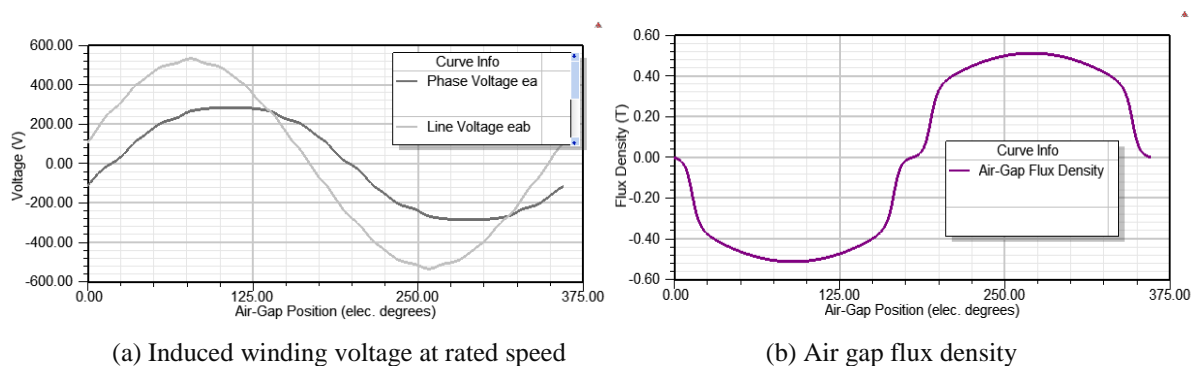

Fig. 3. Back EMF and air gap flux density of analyzed motor

3. Results and discussion

3.1 Operation with a rated speed

Firstly, the simulation model is set for operating with the rated speed (i.e. 1,500 rpm or 157 rad/s). The motor operates with step load, i.e. 0.35 seconds after the acceleration has finished the step load of 14 Nm is coupled to the motor shaft. The presented Simulink model in Fig.1 is universal and can be easily adapted to any synchronous motor with round type rotor by inputting parameters of the stator winding (resistance and inductance) as well as a number of pair of poles and moment of inertia. The obtained results of motor speed, torque, and current

at step load of 14 Nm is presented in Fig. 4. As expected, the motor accelerates and reaches the synchronous speed of 157 rad/s at 0.15 seconds. After 0.35 seconds the step load of 14 Nm is applied to the motor shaft. The motor continues to operate with synchronous speed without losing the synchronism. The motor torque after the acceleration drops down to the no-load torque and quickly increases again to the rated torque of 14 Nm when the step load is coupled to the motor shaft. Similar behavior can be observed in the transient characteristic of motor current, the current decreases to the no-load current (0.26 A for the analyzed motor) and later quickly rise again to the rated current (app. 3.5 A rms value) when the rated load is applied to the motor shaft. Obtained results of current from simulation model correspond to the presented data in Table 1.

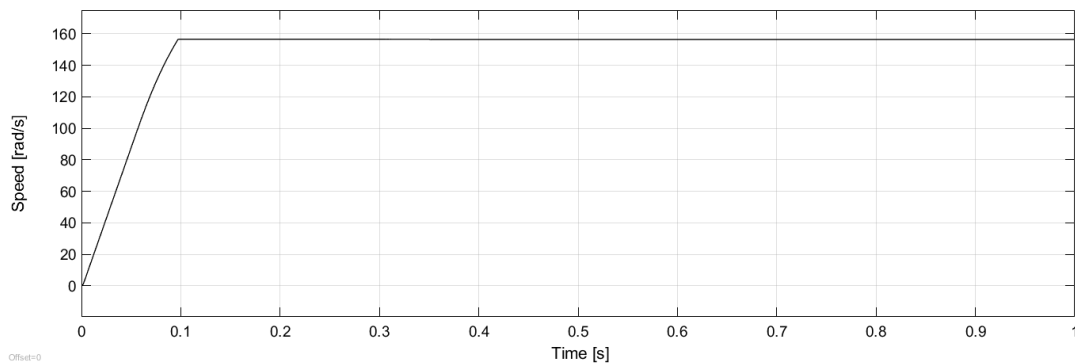

(a) speed

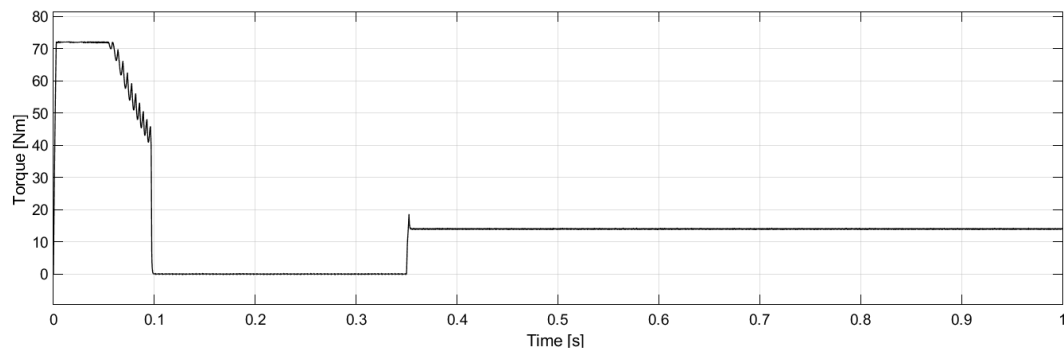

(b) torque

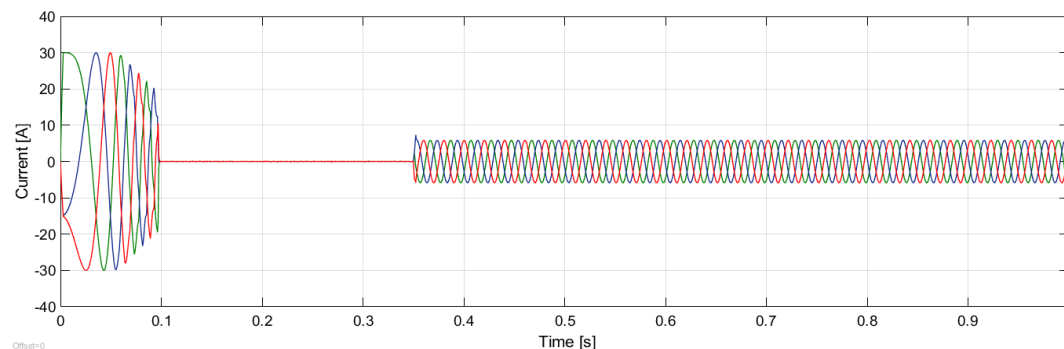

(c) current

Fig. 4. Transient characteristics at rated speed and with a step load of 14 Nm

3.2 Operation above rated speed

Permanent magnet synchronous motors have a single stator winding which generates a current phasor I . This current phasor can be split into the two components along the d- and q-axis, I_d and I_q [4].

$$I = \sqrt{I_d^2 + I_q^2} \quad (1)$$

However, in permanent magnet machines, the flux is produced by permanent magnets, thus the magnetic field (excitation) or magnetic flux cannot be controlled by varying the field current. The permanent magnets are considered as “fixed excitation flux” sources Ψ_m . Therefore, control of the excitation field (flux control or field-weakening) is achieved by introducing an opposing field Ψ_F against the fixed excitation from the permanent magnets. It is achieved by injecting a negative d-current I_d (or field current I_F), as shown in Fig. 5 [4].

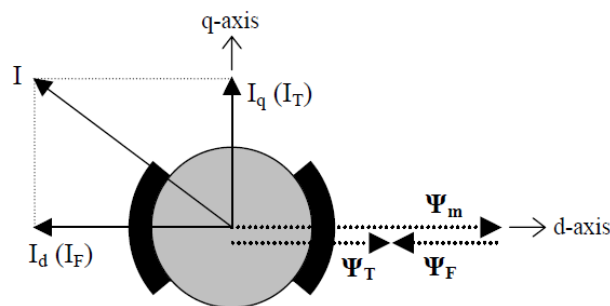

Fig. 5. Transient characteristics at rated speed and with step load [4]

Figure 6 (a) shows the voltage phasor diagram when the motor is running at a low speed well below the rated speed. When the motor is operated at rated conditions, as shown in Figure 6 (b), it can be noted that the voltage vector is on the voltage limit contour (maximum voltage U_b). It is virtually impossible to increase the speed by keeping a current I along the q-axis once the induced voltage E equals the rated voltage.

To increase the speed beyond this limit, the current phasor should be rotated towards the negative d-axis (introduction of a negative d-axis current I_d). Figure 6 (c) shows that the voltage vector U is kept within the voltage limit [4].

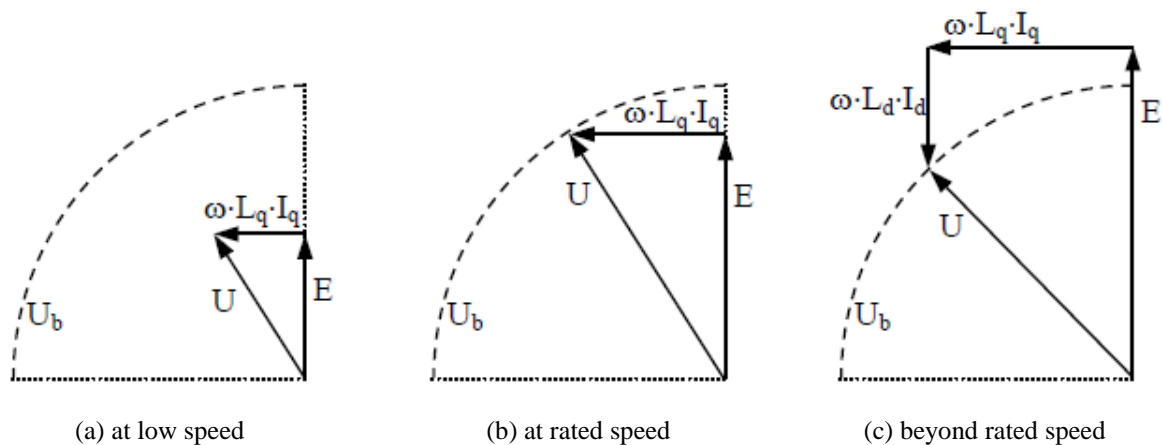

Fig. 6. Voltage phasor diagram of PMSM [4]

For the analyzed motor beyond the rated speeds of 1,500 rpm or 157 rad/s, the effect of field weakening is present, and the torque decreases as the motor speed increases to maintain the constant power. The effect of the field weakening for the analyzed motor is shown in Fig.7. It is based on the analytical calculation of the motor in the program Ansys and predicts the motor behavior and operation above the rated speed in terms of the steady-state characteristics.

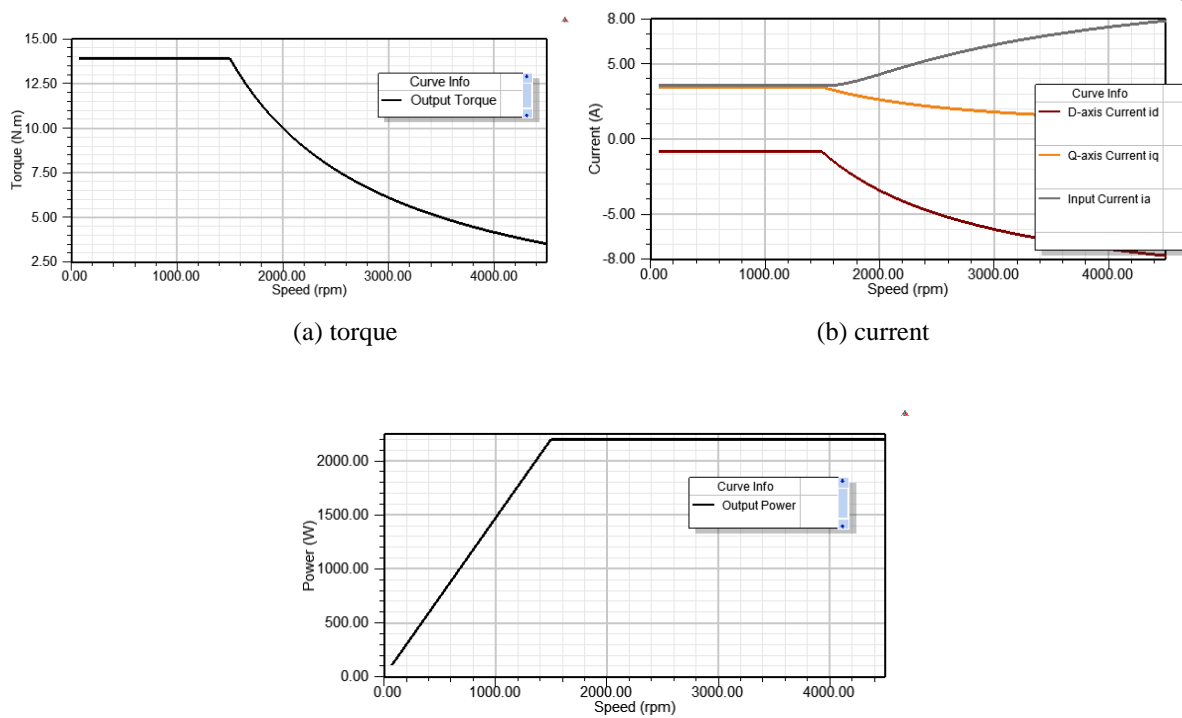
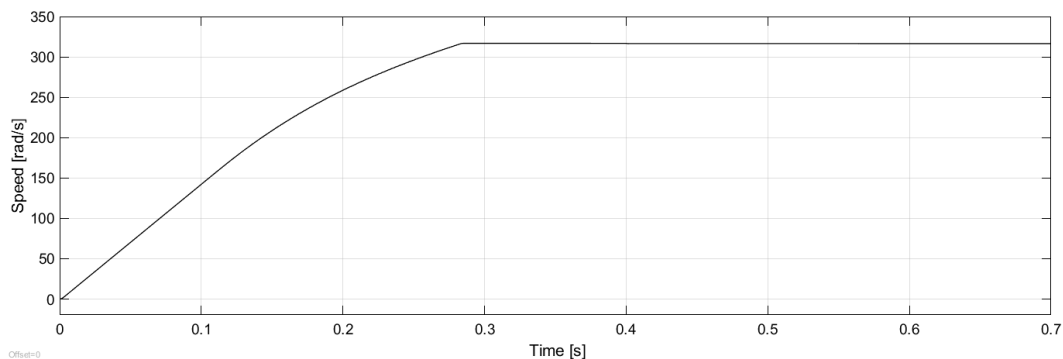

Fig. 7. Characteristics of torque, speed, and power of the analyzed motor in field weakening operation

In the Simulink circuit, the motor speed is set to 314 rad/s. The step load of 7 Nm is coupled to the motor shaft 0.3 seconds after the start of the motor. The obtained characteristics of torque, speed, and current are presented in Fig. 8. The motor can maintain synchronism with a load of 7 Nm at 314 rad/s speed or 3,000 rpm. According to Fig. 7 (a), the torque reduction in the field weakening region at 3,000 rpm is at 6 Nm. The obtained result of torque from simulation differs slightly from the analytical result of 6 Nm. This is due to the simulation circuit in which the obtained torque is electromagnetic torque, slightly bigger than motor output torque presented in Fig. 7 (a). The result of current obtained from Simulink is within the expected value of 7 A rms value. A similar result is obtained for Fig. 7 (b) where at 3,000 rpm the motor current is 7 A. Obtained results from Simulink are in good agreement with the results from the analytical calculation of the motor (steady-state characteristics).

Finally, the step load of 8 Nm is applied to the motor shaft and the obtained results are presented in Fig. 9. As can be seen from Fig. 9 because of flux weakening, the motor cannot operate under this load, i.e. the motor loses the synchronism (Fig. 9).



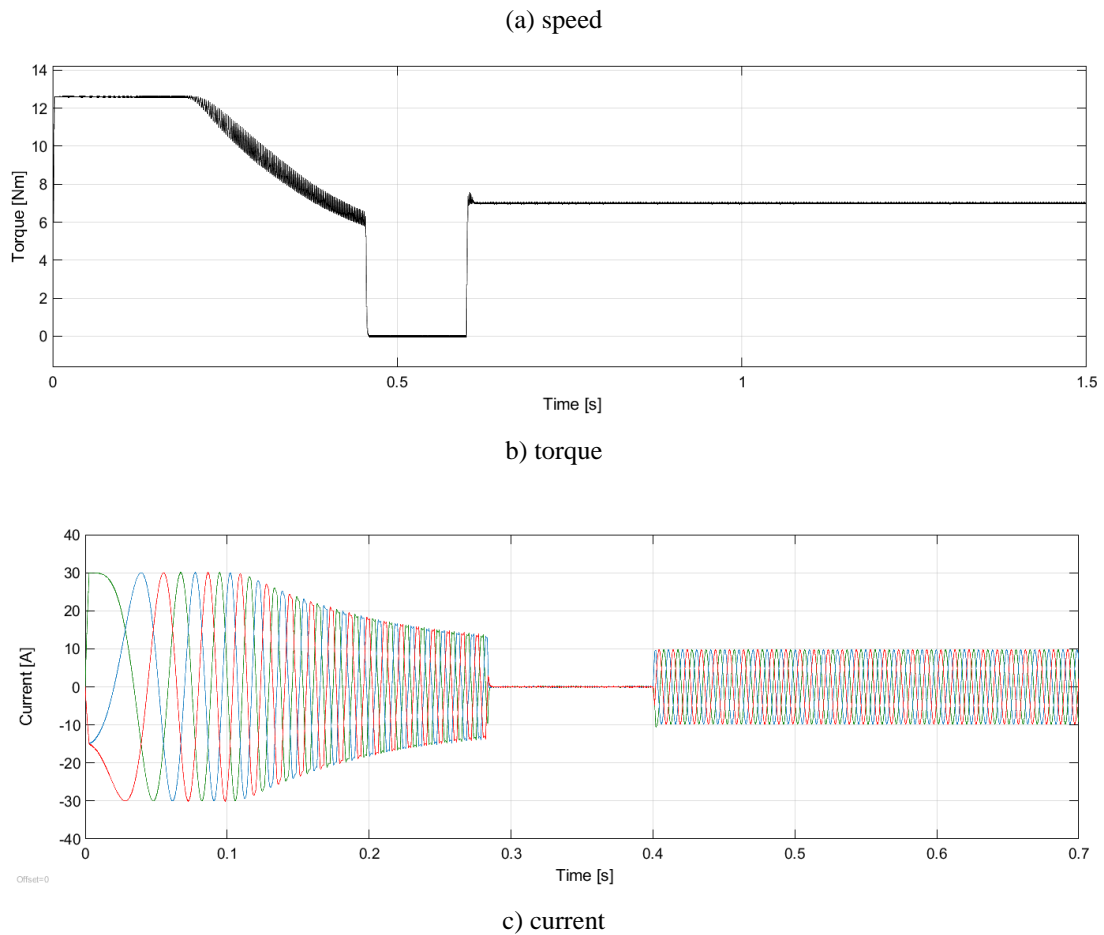

Fig. 8. Transient characteristics beyond the rated speed and with a step load of 7 Nm

The stator currents are quite "noisy," which is expected when using PWM inverters. The noise introduced by the PWM inverter is also observed in the waveform of torque. However, the motor's inertia prevents this noise from appearing in the motor's speed waveform [5].

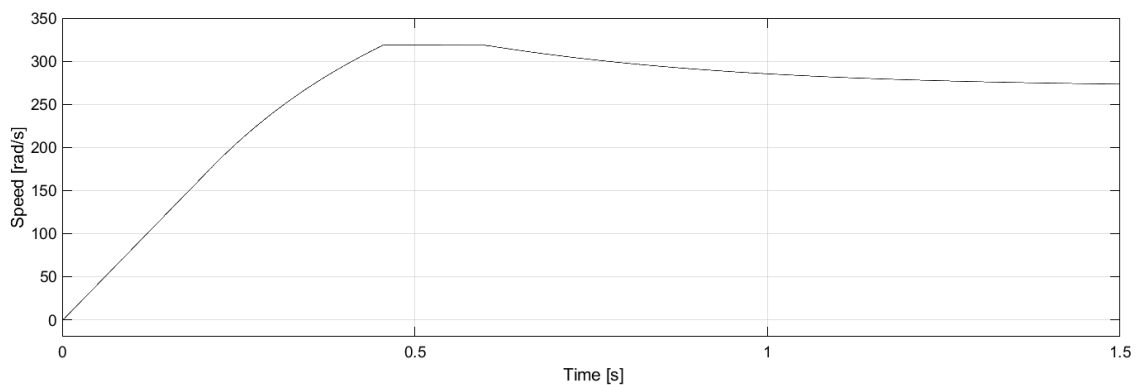

Fig. 9. Loss of synchronism at 8 Nm due to field-weakening

Conclusions

The synchronous permanent magnet motor with embedded or surface-mounted magnet always operates together with the inverter, used for motor starting but also motor operation with variable speed. Up to the rated speed, the motor operation is determined by the rated parameters of the motor. Beyond the rated speed, the effect of field weakening decreases the motor torque and the motor enters the so-called region of operation with constant power. As the speed increases, to maintain constant power, the motor torque decreases.

The paper also illustrates the operation of synchronous motor with inverter at rated speed and above it. Above the rated speed, motor enters the field weakening region which can be observed from the reduced capability of the motor to operate under various loads. The obtained transient characteristics of speed torque and current determine the motor dynamic behavior at two different speeds and with various step loads applied to the motor shaft. The obtained transient characteristics (i.e. values of current, speed and torque) are compared with motor data from the analytical calculation (steady-state characteristics) and this comparison shows reasonable agreement between both methods. The used simulation circuit from Simulink is universal and can be easily adapted to any synchronous motor by entering the adequate motor parameters. It is a useful tool in analysis of motor dynamics.

Further research should be focused on improvement of harmonic content and elimination of harmonics present in motor current due to the power supply from the inverter. Often, they are the source of additional losses and overheating of the motor which makes the operation of the synchronous motor with the inverter more complex and increases the operational costs.

References

- [1] Baek, Soo-Whang / Lee, Sang Wook: “Design Optimization and Experimental Verification of Permanent Magnet Synchronous Motor Used in Electric Compressors in Electric Vehicles”, *Applied Sciences*, 10 (3235), 2020, pp. 1-16.
- [2] He, Ren/ Han, Qingzhen: “Dynamics and Stability of Permanent-Magnet Synchronous Motor”, *Mathematical Problems in Engineering*, Volume 2017, 2017, pp. 1-8.
- [3] Levkin Dimitry: “Permanent Magnet Synchronous Motor”, *Engineering Solutions*, 2021, available at: <https://en.engineering-solutions.ru/motorcontrol/pmsm>
- [4] Meier, Stephan: “Theoretical design of surface-mounted permanent magnet motors with field weakening capability”, Master Thesis, Stockholm, 2002.
- [5] Mathworks, Matlab 2018b
- [6] Soong, Wen L. / Ertugrul, Nesimi: “Field-Weakening Performance of Interior Permanent-Magnet Motors”, *IEEE Transactions on Industry Applications*, 38 (5), 2002, pp. 1251-1258.
- [7] Jerčić, Tino, et al: “Constrained field-oriented control of permanent synchronous machine with field-weakening utilizing a reference governor”, *Automatika*, 58(3), 2017, pp. 439-449.
- [8] Zhou, Kai et al “Field Weakening Operation Control Strategies of PMSM Based on Feedback Linearization” *Energies*, 12 (4526), 2019, pp 1-18.
- [9] Zhu, Jianguang / Chu, Xu: “Research on Control Methods of Six-phase Permanent Magnet Synchronous Motor”, *IOP Conf. Series: Materials Science and Engineering*, 790, 2020, pp 1-7.