

**GOCE DELCEV UNIVERSITY, SHTIP, NORTH MACEDONIA
FACULTY OF ELECTRICAL ENGINEERING**

ETIMA 2021

FIRST INTERNATIONAL CONFERENCE

19-21 OCTOBER, 2021



**TECHNICAL SCIENCES APPLIED IN ECONOMY,
EDUCATION AND INDUSTRY**



УНИВЕРЗИТЕТ „ГОЦЕ ДЕЛЧЕВ” - ШТИП
ЕЛЕКТРОТЕХНИЧКИ ФАКУЛТЕТ

UNIVERSITY „GOCE DELCHEV” - SH TIP
FACULTY OF ELECTRICAL ENGINEERING

ПРВА МЕЃУНАРОДНА КОНФЕРЕНЦИЈА
FIRST INTERNATIONAL CONFERENCE

ЕТИМА / ЕТИМА 2021

ЗБОРНИК НА ТРУДОВИ
CONFERENCE PROCEEDINGS

19-21 Октомври 2021 | 19-21 October 2021

Главен и одговорен уредник / Editor in Chief

Проф.д-р Сашо Гелев
Prof.d-r Saso Gelev

Јазично уредување / Language Editor

Весна Ристова (Македонски) / Vesna Ristova (Macedonian)

Техничко уредување / Technical Editing

Доц.д-р Далибор Серафимовски / d-r Dalibor Serafimovski

Издавач / Publisher

Универзитет „Гоце Делчев“ - Штип / University Goce Delchev - Stip
Електротехнички факултет / Faculty of Electrical Engineering

Адреса на организационен комитет / Adress of the organizational committee

Универзитет „Гоце Делчев“ – Штип / University Goce Delchev - Stip
Електротехнички факултет / Faculty of Electrical Engineering
Адреса: ул. „Крсте Мисирков“ бр. 10-А / Adress: Krste Misirkov, 10 - A
Пош. фах 201, Штип - 2000, С.Македонија / PO BOX 201, Stip 2000, North Macedonia
E-mail: conf.etf@ugd.edu.mk

CIP - Каталогизација во публикација
Национална и универзитетска библиотека "Св. Климент Охридски", Скопје

62-049.8(062)
004-049.8(062)

МЕЃУНАРОДНА конференција ЕТИМА (1 ; 2021)
Зборник на трудови [Електронски извор] / Прва меѓународна
конференција ЕТИМА 2021, 19-21 Октомври 2021 = Conference proceedings /
First international conferece ЕТИМА 2021, 19-21 October 2021 ; [главен и
одговорен уредник Сашо Гелев]. - Штип: Универзитет "Гоце Делчев",
Електротехнички факултет = Shtip: University "Goce Delchev", Faculty of
Electrical Engineering, 2021

Начин на пристапување (URL): <https://js.ugd.edu.mk/index.php/etima>. -
Текст во PDF формат, содржи 358 стр.илустр. - Наслов преземен од
екранот. - Опис на изворот на ден 15.10.2021. - Трудови на мак. и англ.
јазик. - Библиографија кон трудовите

ISBN 978-608-244-823-7

1. Напор. ств. насл.

а) Електротехника -- Примена -- Собири б) Машинство -- Примена -- Собири
в) Автоматика -- Примена -- Собири г) Информатика -- Примена -- Собири

COBISS.MK-ID 55209989



Прва меѓународна конференција ЕТИМА
19-21 Октомври 2021
First International Conference ETIMA
19-21 October 2021

**ОРГАНИЗАЦИОНЕН ОДБОР
ORGANIZING COMMITTEE**

Василија Шарац / Vasilija Sarac

Електротехнички факултет,
Универзитет „Гоце Делчев“ - Штип, Северна Македонија
Faculty of Electrical Engineering,
Goce Delchev University - Stip, North Macedonia

Сашо Гелев / Saso Gelev

Електротехнички факултет,
Универзитет „Гоце Делчев“ - Штип, Северна Македонија
Faculty of Electrical Engineering,
Goce Delchev University - Stip, North Macedonia

Тодор Чекеровски / Todor Cekerovski

Електротехнички факултет,
Универзитет „Гоце Делчев“ - Штип, Северна Македонија
Faculty of Electrical Engineering,
Goce Delchev University - Stip, North Macedonia

Далибор Серафимовски / Dalibor Serafimovski

Електротехнички факултет,
Универзитет „Гоце Делчев“ - Штип, Северна Македонија
Faculty of Electrical Engineering,
Goce Delchev University - Stip, North Macedonia

Маја Кукушева Панева / Maja Kukuseva Paneva

Електротехнички факултет,
Универзитет „Гоце Делчев“ - Штип, Северна Македонија
Faculty of Electrical Engineering,
Goce Delchev University - Stip, North Macedonia

Билјана Читкушева Димитровска / Biljana Citkuseva Dimitrovska

Електротехнички факултет,
Универзитет „Гоце Делчев“ - Штип, Северна Македонија
Faculty of Electrical Engineering,
Goce Delchev University - Stip, North Macedonia

Весна Конзулова / Vesna Konzulova

Електротехнички факултет,
Универзитет „Гоце Делчев“ - Штип, Северна Македонија
Faculty of Electrical Engineering,
Goce Delchev University - Stip, North Macedonia



Прва меѓународна конференција ЕТИМА
19-21 Октомври 2021
First International Conference ETIMA
19-21 October 2021

**ПРОГРАМСКИ И НАУЧЕН ОДБОР
SCIENTIFIC COMMITTEE**

Со Ногучи / So Noguchi

Висока школа за информатички науки и технологии
Универзитет Хокаидо, Јапонија
Graduate School of Information Science and Technology
Hokkaido University, Japan

Диониз Гашпаровски / Dionýz Gašparovský

Факултет за електротехника и информатички технологии,
Словачки Технички Универзитет во Братислава, Словачка
Faculty of Electrical Engineering and Information Technology
Slovak Technical University in Bratislava, Slovakia

Антон Белан / Anton Belán

Факултет за електротехника и информатички технологии
Словачки Технички Универзитет во Братислава, Словачка
Faculty of Electrical Engineering and Information Technology
Slovak Technical University in Bratislava, Slovakia

Георги Иванов Георгиев / Georgi Ivanov Georgiev,

Технички Универзитет во Габрово, Бугарија
Technical University in Gabrovo, Bulgaria

Ивелина Стефанова Балабанова / Ivelina Stefanova Balabanova,

Технички Универзитет во Габрово, Бугарија
Technical University in Gabrovo, Bulgaria

Бојан Димитров Карапeneв / Boyan Dimitrov Karapenev

Технички Универзитет во Габрово, Бугарија
Technical University in Gabrovo, Bulgaria

Сашо Гелев / Saso Gelev

Електротехнички факултет,
Универзитет „Гоце Делчев“ - Штип, Северна Македонија
Faculty of Electrical Engineering,
Goce Delchev University - Stip, North Macedonia

Влатко Чингоски / Vlatko Cingoski
Електротехнички факултет,
Универзитет „Гоце Делчев” - Штип, Северна Македонија
Faculty of Electrical Engineering,
Goce Delchev University - Stip, North Macedonia

Божо Крстајиќ / Bozo Krstajic
Електротехнички факултет
Универзитет во Црна Гора, Црна Гора
Faculty of Electrical Engineering,
University in Montenegro, Montenegro

Милован Радуловиќ / Milovan Radulovic
Електротехнички факултет
Универзитет во Црна Гора, Црна Гора
Faculty of Electrical Engineering,
University in Montenegro, Montenegro

Гоце Стефанов / Goce Stefanov
Електротехнички факултет,
Универзитет „Гоце Делчев” - Штип, Северна Македонија
Faculty of Electrical Engineering,
Goce Delchev University - Stip, North Macedonia

Мирјана Перик / Mirjana Peric
Електронски факултет
Универзитет во Ниш, Србија
Faculty of Electronic Engineering,
University of Nis, Serbia

Ана Вучковиќ / Ana Vuckovic
Електронски факултет
Универзитет во Ниш, Србија
Faculty of Electronic Engineering,
University of Nis, Serbia

Тодор Чекеровски / Todor Cekеровски
Електротехнички факултет,
Универзитет „Гоце Делчев” - Штип, Северна Македонија
Faculty of Electrical Engineering,
Goce Delchev University - Stip, North Macedonia

Далибор Серафимовски / Dalibor Serafimovski
Електротехнички факултет,
Универзитет „Гоце Делчев” - Штип, Северна Македонија
Faculty of Electrical Engineering,
Goce Delchev University - Stip, North Macedonia

Мирослава Фаркаш Смиткова / Miroslava Farkas Smitková

Факултет за електротехника и информации технологии
Словачки Технички Универзитет во Братислава, Словачка
Faculty of Electrical Engineering and Information Technology
Slovak Technical University in Bratislava, Slovakia

Петер Јанига / Peter Janiga

Факултет за електротехника и информации технологии
Словачки Технички Универзитет во Братислава, Словачка
Faculty of Electrical Engineering and Information Technology
Slovak Technical University in Bratislava, Slovakia

Јана Радичова / Jana Raditschová,

Факултет за електротехника и информации технологии
Словачки Технички Универзитет во Братислава, Словачка
Faculty of Electrical Engineering and Information Technology
Slovak Technical University in Bratislava, Slovakia

Драган Миновски / Dragan Minovski

Електротехнички факултет,
Универзитет „Гоце Делчев” - Штип, Северна Македонија
Faculty of Electrical Engineering,
Goce Delchev University - Stip, North Macedonia

Василија Шарац / Vasilija Sarac

Електротехнички факултет,
Универзитет „Гоце Делчев” - Штип, Северна Македонија
Faculty of Electrical Engineering,
Goce Delchev University - Stip, North Macedonia

Александар Туцаров / Aleksandar Tudzarov

Електротехнички факултет,
Универзитет „Гоце Делчев” - Штип, Северна Македонија
Faculty of Electrical Engineering,
Goce Delchev University - Stip, North Macedonia

Владимир Талевски / Vladimir Talevski

Електротехнички факултет,
Универзитет „Гоце Делчев” - Штип, Северна Македонија
Faculty of Electrical Engineering,
Goce Delchev University - Stip, North Macedonia



Прва меѓународна конференција ЕТИМА First International Conference ETIMA

PREFACE

The Faculty of Electrical Engineering at University Goce Delcev (UGD), has organized the International Conference *Electrical Engineering, Informatics, Machinery and Automation - Technical Sciences applied in Economy, Education and Industry-ETIMA*.

ETIMA has a goal to gather the scientists, professors, experts and professionals from the field of technical sciences in one place as a forum for exchange of ideas, to strengthen the multidisciplinary research and cooperation and to promote the achievements of technology and its impact on every aspect of living. We hope that this conference will continue to be a venue for presenting the latest research results and developments on the field of technology.

Conference ETIMA was held as online conference where contributed more than sixty colleagues, from six different countries with forty papers.

We would like to express our gratitude to all the colleagues, who contributed to the success of ETIMA'21 by presenting the results of their current research activities and by launching the new ideas through many fruitful discussions.

We invite you and your colleagues also to attend ETIMA Conference in the future. One should believe that next time we will have opportunity to meet each other and exchange ideas, scientific knowledge and useful information in direct contact, as well as to enjoy the social events together.

The Organizing Committee of the Conference

ПРЕДГОВОР

Меѓународната конференција *Електротехника, Технологија, Информатика, Машинство и Автоматика-технички науки во служба на економија, образование и индустрија-ЕТИМА* е организирана од страна на Електротехничкиот факултет при Универзитетот Гоце Делчев.

ЕТИМА има за цел да ги собере на едно место научниците, професорите, експертите и професионалците од полето на техничките науки и да представува форум за размена на идеи, да го зајканува мултидисциплинарното истражување и соработка и да ги промовира технолошките достигнувања и нивното влијание врз секој аспект од живеењето. Се надеваме дека оваа конференција ќе продолжи да биде настан на кој ќе се презентираат најновите резултати од истражувањата и развојот на полето на технологијата.

Конференцијата ЕТИМА се одржа online и на неа дадоа свој допринос повеќе од шеесет автори од шест различни земји со четириесет труда.

Сакаме да ја искажеме нашата благодарност до сите колеги кои допринесоа за успехот на ЕТИМА'21 со презентирање на резултати од нивните тековни истражувања и со лансирање на нови идеи преку многу плодни дискусии.

Ве покануваме Вие и Вашите колеги да земете учество на ЕТИМА и во иднина. Веруваме дека следниот пат ќе имаме можност да се сретнеме, да размениме идеи, знаење и корисни информации во директен контакт, но исто така да уживаме заедно и во друштвените настани.

Организационен одбор на конференцијата

Содржина / Table of Contents

ASSESSING DIGITAL SKILLS AND COMPETENCIES OF PUBLIC ADMINISTRATION AND DEFINING THEIR PROFICIENCY LEVEL.....	12
PWM OPERATION OF SYNCHRONOUS PERMANENT MAGNET MOTOR.....	21
SPEED REGULATION OF INDUCTION MOTOR WITH PWM INVERTER.....	30
WI-FI SMART POWER METER	42
RF SENSOR SMART NETWORK.....	50
FREQUENCY SINUS SOURCE.....	62
MEASUREMENT ON COMPENSATION CAPACITANCE IN INDUCTIVE NETWORK BY MICROCONTROLLER	70
ИЗРАБОТКА НА ВЕШТ НАОД И МИСЛЕЊЕ ОД ОБЛАСТА НА ЕЛЕКТРОТЕХНИЧКИТЕ НАУКИ.....	79
SIMULATION OF AN INDUSTRIAL ROBOT WITH THE HELP OF THE MATLAB SOFTWARE PACKAGE.....	86
BATTERY ENERGY STORAGE SYSTEMS AND TECHNOLOGIES:A REVIEW ..	95
POWER-TO-X TECHNOLOGIES.....	105
NEW INNOVATIVE TOURISM PRODUCT FOR REANIMATING RURAL AREAS	115
PROPOSED MODEL FOR BETTER ENGLISH LANGUAGE ACQUISITION, BASED ON WEARABLE DEVICES.....	123
OPEN SOURCE LEARNING PLATFORM – MOODLE	132
СПОРЕДБЕНА ТЕХНО-ЕКОНОМСКА АНАЛИЗА ПОМЕЃУ ТЕРМИЧКИ ИЗОЛИРАН И ТЕРМИЧКИ НЕИЗОЛИРАН СТАНБЕН ОБЈЕКТ	139
COMPARISON OF PERT AND MONTE CARLO SIMULATION	149
E-LEARNING – CYBER SECURITY CHALLENGES AND PROTECTION MECHANISMS	156
SECURITY AND PRIVACY WITH E-LEARNING SOFTWARE.....	164
ROOTKITS – CYBER SECURITY CHALLENGES AND MECHANISMS FOR PROTECTION	174
TOOLS AND TECHNIQUES FOR MITIGATION AND PROTECTION AGAINST SQL INJECTION ATTACKS	182
INFLUENCE OF ROTATION ANGLE OF LUMINAIRES WITH ASYMMETRICAL LUMINOUS INTENSITY DISTRIBUTION CURVE ON CALCULATED PHOTOMETRIC PARAMETERS.....	189
PHOTOMETRIC PARAMETERS OF LED LUMINAIRES WITH SWITCHABLE CORRELATED COLOUR TEMPERATURE	197
ENERGY-EFFICIENT STREET LIGHTING SYSTEM OF THE CITY OF SHIP USING SOLAR ENERGY AND LED TECHNOLOGY.....	204
NANOTECHNOLOGY–BASED BIOSENSORS IN DRUG DELIVERY SYSTEMS: A REVIEW.....	212

IOT SYSTEM FOR SHORT-CIRCUIT DETECTION OF DC MOTOR AT EKG-15 EXCAVATOR	222
DESIGN OF A PHOTOVOLTAIC POWER PLANT	231
DEVELOPMENT OF COMPUTER SOFTWARE FOR CREATING CHOREOGRAPHY	241
AUTOMATED SYSTEM FOR SMART METER TESTING.....	249
INFLUENCE DIMING OF LED LAMPS TO ELECTRICAL PARAMETERS	255
INRUSH CURRENT OF LAMP.....	261
COMPLEX EVALUATION MODEL OF A SMALL-SCALE PHOTOVOLTAIC INSTALLATION PROFITABILITY	269
IMPACT OF FAULTS IN TRANSMISSION AND DISTRIBUTION NETWORK ON VOLTAGE SAGS	278
ON APPLICABILITY OF BLACK-SCHOLES MODEL TO MSE	290
ACOUSTIC SIGNAL DENOISING BASED ON ROBUST PRINCIPAL COMPONENT ANALYSIS	300
INVESTIGATION OF EFFICIENCY ASPECTS IN 3×3 PHOTOVOLTAIC PLANT USING MODEL OF SHADING	309
PROGRESS OF NO-INSULATION HTS MAGNET DEVELOPMENT TOWARDS ULTRA-HIGH MAGNETIC FIELD GENERATION.....	319
GRID-CONNECTED HYBRID PV SYSTEM WITH BATTERY STORAGE.....	326
INVESTIGATION ON STABILITY OF PANCAKE COILS WOUND WITH BUNDLED MULTIPLE REBCO CONDUCTORS	336
ON-LINE МУЛТИМЕДИСКИ ОБРАЗОВНИ КАРТИЧКИ	343
АЛГОРИТАМОТ „ВЕШТАЧКА КОЛОНИЈА НА ПЧЕЛИ“	352



WI-FI SMART POWER METER

Goce Stefanov¹, Vlatko Cingoski²

¹Faculty of Electrical Engineering University Goce Delcev Stip R.Macedonia, goce.stefanov@ugd.edu.mk

²Faculty of Electrical Engineering University Goce Delcev Stip R.Macedonia, vlatko.cingoski@ugd.edu.mk

Abstract

In the paper are presents the results of a practically realized on process Smart Power meter. The application is intended for data collection for the voltage, the current in processing plants. By processing them, data on power, energy, frequency and power factor are obtained. These quantities are visualized on an LCD display, stored in an excel log file, and are distributed on the Internet via a WI-FI interface. The solution was realized with the smart power module PEZ004 and Node MCU ESP 8266.

Key words

Power meter, WI-FI, Data Log.

1. Introduction

The data for energy consumption in industrial process plants are essential for the efficient operation of the work process. On the basis of the data on the consumed energy, on the one hand the production process can be planned, and on the other hand it is possible to take measures to improve the efficiency and reduce the energy consumption [1], [2].

Built-in devices for measuring energy and power depend on the degree of development of the measurement technique at the moment of realization of the industrial process. Thanks to the development of the electronics, today's energy and power measurement systems enable the measurement values of process quantities to be visualized on display, sent remotely and stored in a file compatible for future user processing [3], [4]. In the Fig. 1 is shown block diagram on one smart power system for energy and power measurements.

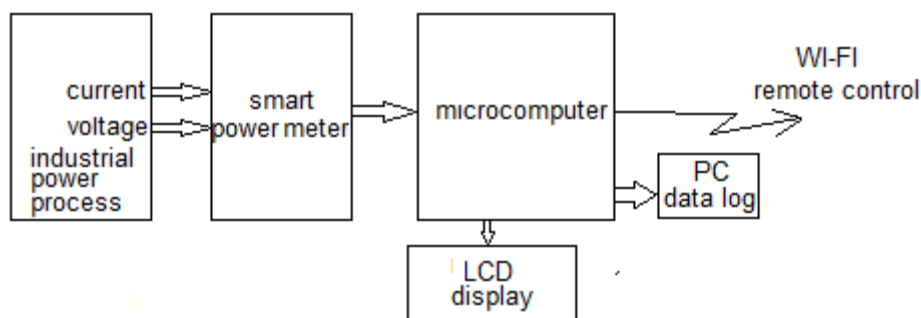

Fig. 1. Block diagram on one smart power system for energy and power measurements.

From Fig. 1 can be see that smart power system is based on microcomputer. It collects data on the quantities of current and voltage in industrial power process and calculated data for energy and power. The microcomputer sends this data to the Internet with a Wi-Fi modem [4]. The microcomputer with the UART port it is connected to a personal computer to which it sends the data to the Intra network. This hardware architecture provides on the one hand the data adequate for energy consumption in the industrial power process to be collected and visualized

on LCD displays and on a personal computer, and on the other hand the possibility for distribution of data in the Internet network is created.

2. Design on Wi-Fi smart power meter

In this part an WI-FI smart power meter is designed. The designed solution will collect data for the current from current transformer and the voltage on which is connected device in industrial power process. In the Fig. 2 is shown block diagram of the specific solution of WI-FI smart power meter.

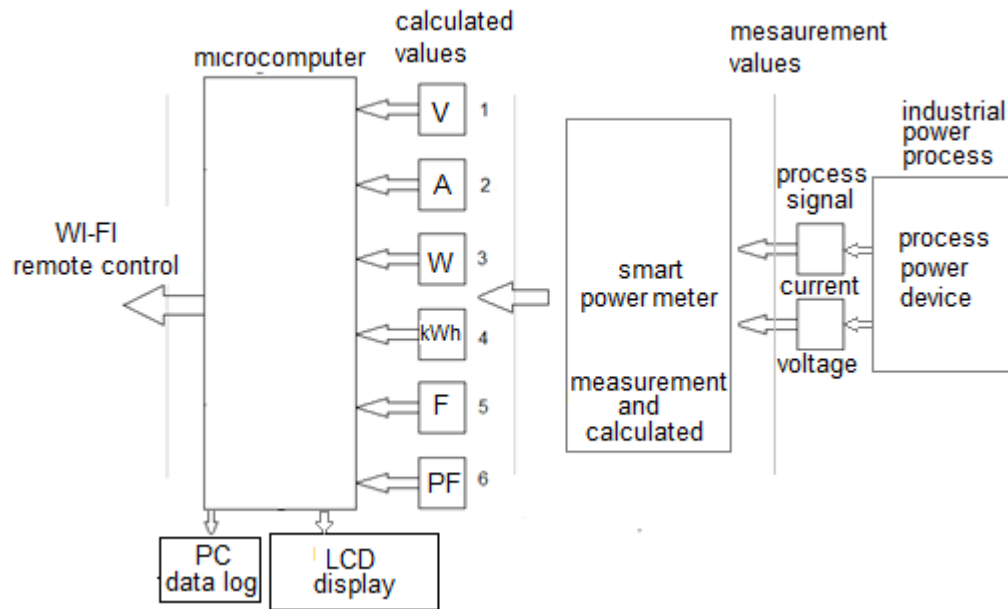

Fig. 2. Block diagram of the specific solution of WI-FI smart power meter.

The main part of this WI-FI smart power meter is the microcomputer. In the solution is selected the NodeMCU ESP8266 [5], [6]. Smart power meter takes data on the current and the voltage from the power device. The current data is taken with a current transformer. The voltage data is obtained from the voltage of the device terminals. Based on the current and voltage, the power meter calculates power, energy, frequency and power factor and sends it to the microcomputer together with the current and voltage data. In the fig. 2 calculated values are marked as: 1 is the data for voltage marked as V, 2 is the data for current marked as A, 3 is the data for power marked as W, 4 is the data for energy marked as kWh, 5 is the data for frequency marked as F and 6 is the data for power factor marked as PF. The power meter is connected to the microcomputer with the serial port. The microcomputer sends data on the current values of the quantities, on a personal computer, compatible in an excel file and also sends these quantities to the Internet via a WI-FI connection. In the Fig. 3 is shown the connection diagram of the realized solution.

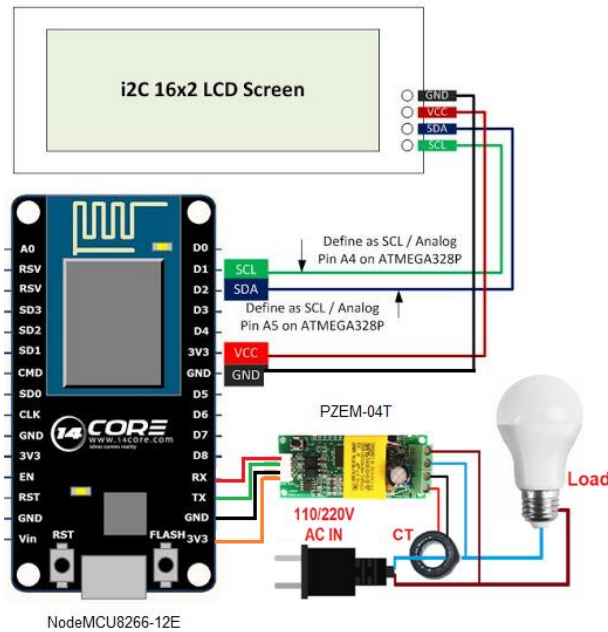

Fig. 3. Connection diagram of the realized solution.

Figure 3 shows that the solution was realized using Node8266MCU and a power meter PZEM 004T.

2.1 Features of the used hardware

a.) Microcomputer NodeMCU ESP8266

The NodeMCU ESP8266 development board comes with the ESP-12E module containing ESP8266 chip having Tensilica Xtensa 32-bit LX106 RISC microprocessor. This microprocessor supports RTOS and operates at 80MHz to 160 MHz adjustable clock frequency. NodeMCU has 128 KB RAM and 4MB of Flash memory to store data and programs. Its high processing power with in-built Wi-Fi / Bluetooth and Deep Sleep Operating features make it ideal for IoT projects. NodeMCU can be powered using Micro USB jack and VIN pin (External Supply Pin). It supports UART, SPI, and I2C interface. In the Fig. 4 is shown NodeMCU ESP8266 and his pinout.

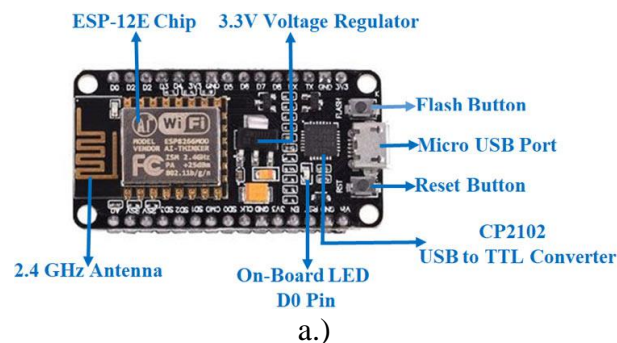

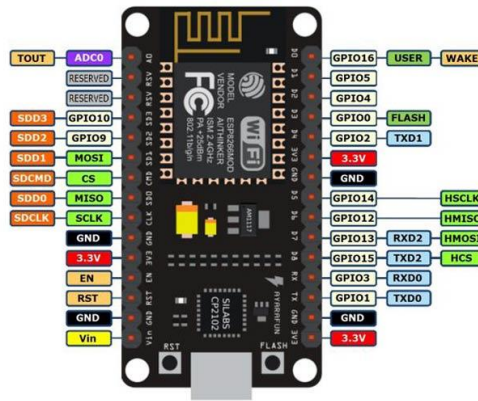

b.)

Fig. 4. a.) NodeMCU ESP8266 and b.) his pinout

NodeMCU is an open-source based firmware and development board specially targeted for IoT based Applications. It includes firmware that runs on the ESP8266 Wi-Fi SoC from Espressif Systems, and hardware which is based on the ESP-12 module.

NodeMCU ESP8266 Specifications & Features

- Microcontroller: Tensilica 32-bit RISC CPU Xtensa LX106
- Operating Voltage: 3.3V
- Input Voltage: 7-12V
- Digital I/O Pins (DIO): 16
- Analog Input Pins (ADC): 1
- UARTs: 1
- SPIs: 1
- I2Cs: 1
- Flash Memory: 4 MB
- SRAM: 64 KB
- Clock Speed: 80 MHz
- USB-TTL based on CP2102 is included onboard, Enabling Plug n Play
- PCB Antenna
- Small Sized module to fit smartly inside your IoT projects

The NodeMCU ESP8266 board can be easily programmed with Arduino IDE since it is easy to use.

In Table 1 is given pinout at this microcomputer.

Table 1: NodeMCU Development Board Pinout Configuration

Pin Category	Name	Description
Power	Micro-USB, 3.3V, GND, Vin	Micro-USB: NodeMCU can be powered through the USB port 3.3V: Regulated 3.3V can be supplied to this pin to power the board GND: Ground pins Vin: External Power Supply
Control Pins	EN, RST	The pin and the button resets the microcontroller
Analog Pin	A0	Used to measure analog voltage in the range of 0-3.3V

GPIO Pins	GPIO1 to GPIO16	NodeMCU has 16 general purpose input-output pins on its board
SPI Pins	SD1, CMD, SD0, CLK	NodeMCU has four pins available for SPI communication.
UART Pins	TXD0, RXD0, TXD2, RXD2	NodeMCU has two UART interfaces, UART0 (RXD0 & TXD0) and UART1 (RXD1 & TXD1). UART1 is used to upload the firmware/program.
I2C Pins		NodeMCU has I2C functionality support but due to the internal functionality of these pins, you have to find which pin is I2C.

b.)Power meter PZEM-004T

The power meter is mainly used for measuring AC voltage, current, active power, frequency, power factor and active energy, the module is without display function, the data is read through the TTL interface. PZEM-004T-10A built-in shunt have measuring range 10A, and PZEM-004T-100A with external transformer have measuring range 100A, [7] . In the fig. 5a is shown the board on PZEM-004T power meter, and Fig. 5b is shown block diagram on this module.

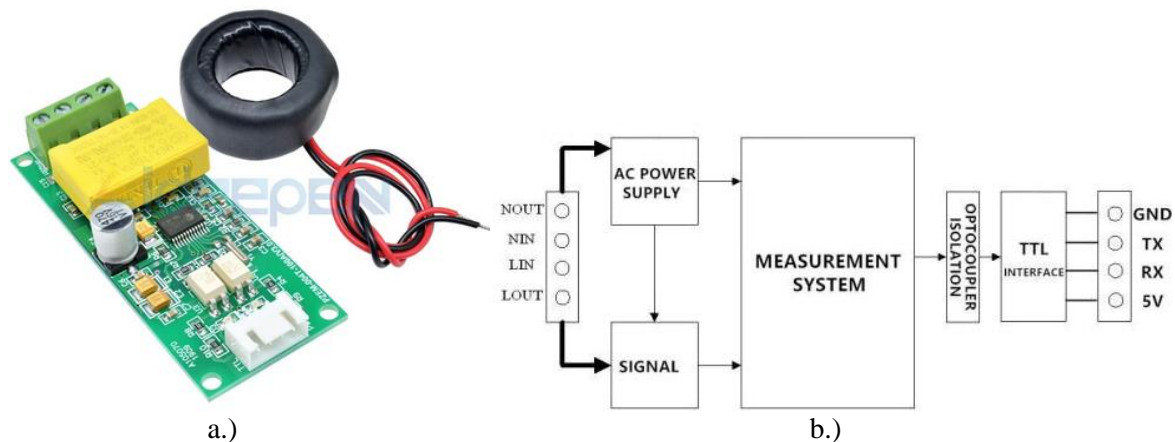

Fig. 5. a.) The board on PZEM-004T power meter, and b.) block diagram on this module.

The current signal is connected to power meter on the terminals NIN and NOUT, and the voltage is connected on the terminals LIN and LOUT. The power meter is supply with 5 VDC voltage. The terminals TX and RX are for serial communication.

Function description

Voltage measuring range is 80~260V.

Current measuring range is 0~10A(PZEM-004T-10A); 0~100A(PZEM-004T-100A)

Active power measuring range is 0~2.3kW(PZEM-004T-10A); 0~23kW(PZEM-004T-100A)

Starting measure power is 0.4W. Resolution is 0.1W.

Display format: < 1000W, it display one decimal, such as: 999.9W. ≥1000W, it display only integer, such as: 1000W. Power factor measuring range is 0.00~1.00 , resolution is 0.01.

Frequency measuring range is 45Hz~65Hz, resolution is 0.1Hz.

Active energy measuring range is 0~9999.99kWh, resolution is 1Wh.

Display format: < 10kWh, the display unit is Wh(1kWh=1000Wh), such as: 9999Wh
 ≥10kWh, the display unit is kWh, such as: 9999.99kWh

Over power alarm

Active power threshold can be set, when the measured active power exceeds the threshold, it

can alarm. Communication interface is RS485 interface.

Communication protocol

Physical layer use UART to RS485 communication interface. Baud rate is 9600, 8 data bits, 1 stop bit, no parity. The application layer use the Modbus-RTU protocol to communicate. At present, it only supports function codes such as 0x03 (Read Holding Register), 0x04 (Read Input Register), 0x06 (Write Single Register), 0x41 (Calibration), 0x42 (Reset energy).etc. 0x41 function code is only for internal use (address can be only 0xF8), used for factory calibration and return to factory maintenance occasions, after the function code to increase 16-bit password, the default password is 0x3721.

The address range of the slave is 0x01 ~ 0xF7. The address 0x00 is used as the broadcast address, the slave does not need to reply the master. The address 0xF8 is used as the general address, this address can be only used in single-slave environment and can be used for calibration etc.operation.

The command format of the master reads the measurement result is(total of 8 bytes): Slave Address + 0x04 + Register Address High Byte + Register Address Low Byte + Number of Registers High Byte + Number of Registers Low Byte + CRC Check High Byte + CRC Check Low Byte.

The command format of the reply from the slave is divided into two kinds: Correct Reply: Slave Address + 0x04 + Number of Bytes + Register 1 Data High Byte + Register 1 Data Low Byte + ... + CRC Check High Byte + CRC Check Low Byte Error Reply: Slave address + 0x84 + Abnormal code + CRC check high byte + CRC check low byte.

3. Experimental results

The design of an WI-FI smart power meter are consists of hardware design and software design.

Hardware design

According to the description of the characteristics of the hardware components given above and the main purpose of the paper, in the Fig. 3 is shows the electrical circuit of the WI-FI smart power meter. The circuit consists of NodeMCU8266-12E, PZEM-004T power meter and LCD display. The operation of the circuit is described in point 2.

Software design

The software is written in micro C. NodeMCU ESP8266 software is compatible with the Arduino IDE platform. The software ensures that the microcomputer receives the signals from the power meter and, after processing, displays the current values on the voltage, current, power, energy, frequency and power factor on LCD display, sends them as a data log file for building a database compatible with an excel file, and distributes them to the WI-FI Internet network.

According to the above, the software consists of several steps.

Defining on variables and libraries:

```
#include <PZEM004Tv30.h>
#include<stdlib.h>
/* ESP & Blynk */
#include <ESP8266WiFi.h>
#include <BlynkSimpleEsp8266.h>
#include <SimpleTimer.h>
#define BLYNK_PRINT Serial // Comment this out to disable prints and save space
#include <LiquidCrystal.h>
#include <Wire.h>
#include <LiquidCrystal_I2C.h>
```

Setting for WI-FI connection:

```

char auth[] = "-DcVhdifI2ct0VC7JpbM4QoWSXEaGthM"; //obtained from APP Store
/* WiFi credentials */
char ssid[] = "my_network"; //defining on WI-FI network
char pass[] = "Elsa1101"; //defining on passport on WI-FI network

```

Building a data log file:

```

Serial.print(value()); // Read value from sensor and send its value to Excel
Serial.print(","); // Move to next column

```

Sending data to GI-FI:

```

Blynk.virtualRead(V3, variable);

```

Reading data on display:

```

lcd.print("name:");
lcd.print(variable);
lcd.print("unit");

```

In the Fig. 6a is shown the experimental prototype on the WI-FI smart power meter, and the Fig. 6b is shown the complete process WI-FI smart power meter. In the Fig. 7a is shown excel data log file.

For remote transmission and display of current values of measurement data in the WI-FI network is built SCADA based on APP Store platform. In the Fig. 7b is shows the screen of an Android mobile device on which are showing the current values of the measurement data.

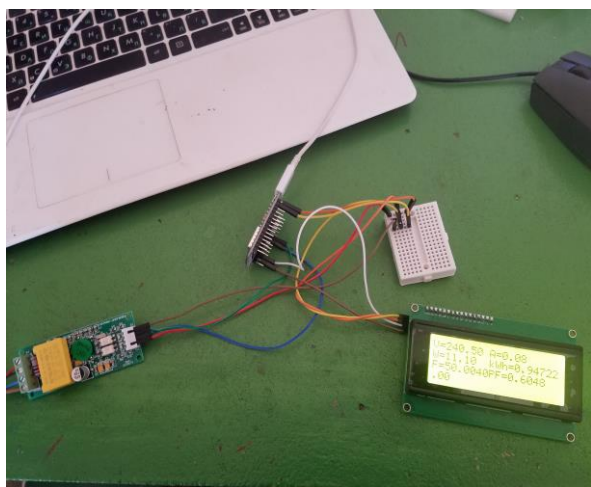

a.)



b.)

Fig. 6. Experimental results: a.) prototype on the WI-FI smart power meter and b.) the complete process WI-FI smart power meter.

Date Stamp	Example In text	Voltage (V)	Current (A)	Power (W)	Energy (kWh)	Frequency (Hz)	PF
4/19/2021		14.33.09	236.5	0.00	10.9	0.30	49.5
4/19/2021		14.33.11	236.5	0.00	11	0.30	49.4
4/19/2021		14.33.14	236.4	0.00	11	0.30	49.5
4/19/2021		14.33.16	236.4	0.00	11	0.30	49.5
4/19/2021		14.33.19	236.5	0.00	11	0.30	49.5
4/19/2021		14.33.21	236.7	0.00	11	0.30	49.5
4/19/2021		14.33.24	236.6	0.00	11	0.30	49.4
4/19/2021		14.33.26	236.7	0.00	11	0.30	49.5
4/19/2021		14.33.29	236.6	0.00	11	0.30	49.4
4/19/2021		14.33.31	236.6	0.00	11	0.30	49.4
4/19/2021		14.33.34	236.6	0.00	11	0.30	49.4
4/19/2021		14.33.36	236.5	0.00	11	0.30	49.4
4/19/2021		14.33.39	236.6	0.00	11	0.30	49.4
4/19/2021		14.33.41	236.6	0.00	11	0.30	49.5
4/19/2021		14.33.44	236.6	0.00	11	0.30	49.5
4/19/2021		14.33.46	236.6	0.00	10.9	0.30	49.4
4/19/2021		14.33.49	236.8	0.00	11	0.30	49.4
4/19/2021		14.33.51	236.8	0.00	10.9	0.30	49.4
4/19/2021		14.33.53	236.4	0.00	11	0.30	49.4
4/19/2021		14.33.56	236.8	0.00	11	0.30	49.4
4/19/2021		14.33.59	236.7	0.00	11	0.30	49.4
4/19/2021		14.34.01	236.6	0.00	11	0.30	49.4
4/19/2021		14.34.03	236.6	0.00	11	0.30	49.4
4/19/2021		14.34.06	236.5	0.00	11	0.30	49.4
4/19/2021		14.34.08	236.6	0.00	11	0.30	49.4
4/19/2021		14.34.11	236.4	0.00	10.9	0.30	49.4
4/19/2021		14.34.13	236.6	0.00	11	0.30	49.4

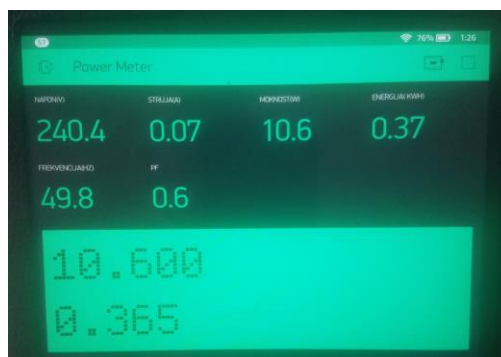

Fig. 7. a.) Excel data log file, b.) screen of an Android mobile device on which are showing the current values of the measurement data.

Conclusions

In the paper with theoretical analysis is designed and practically realized WI-FI smart power meter. The power meter allows data on power, energy, frequency and power factor to be obtained only by measuring the voltage and current of a process device. Then these data are processed, visualized on an LCD screen, sent as a data log in an excel file and distributed remotely via a WI-FI connection. The solution also provides the ability to remote control on the process quantities.

References

- [1] S. Bennett, S. Linkens, Computer Control of Industrial Processes, D.A. (Eds.), IEEE, 1982.
- [2] Ching-Lai Hor and Peter A. Crossley, Knowledge Extraction from Intelligent Electronic Devices, Lecture Notes in Computer Science pp. 82-111, January 2005.
- [3] Teen-Hang Meen, Wenbing Zhao and Cheng-Fu Yang Special Issue on Intelligent Electronic Devices Reprinted from: Electronics 2020, 9, 645.
- [4] By M.A. Matin and M.M. Islam, Wireless Sensor Network, <https://www.intechopen.com/books/wireless-sensor-networks-technology-and-protocols/overview-of-wireless-sensor-network> September 6th 2012, DOI: 10.5772/49376.
- [5] Manoj R. Thakur , NodeMCU ESP8266 Communication Methods and Protocols : Programming with Arduino IDE, 2018.
- [6] ESP8266: Programming NodeMCU Using Arduino IDE - GetStarted With ESP8266, <https://stoveraci.firebaseio.com/aa009/esp8266-programming-nodemcu-using-arduino-ide-get-started-with-esp8266-by-upskill-learning-1534822666.pdf>.
- [7] PZEM004T V3.0 User Manual, <https://innovatorsguru.com/wpcontent/uploads/2019/06/PZEM-004T-V3.0-Datasheet-User-Manual.pdf>